



Honda NSR 500 (Tamiya 14055, 14099) upgrade set

Catalog no.: FSM P006

Installation guide

Parts list: chain x1, thin metal tube x1, thick metal tube x4, thin metal wire, thick metal wire, black wire

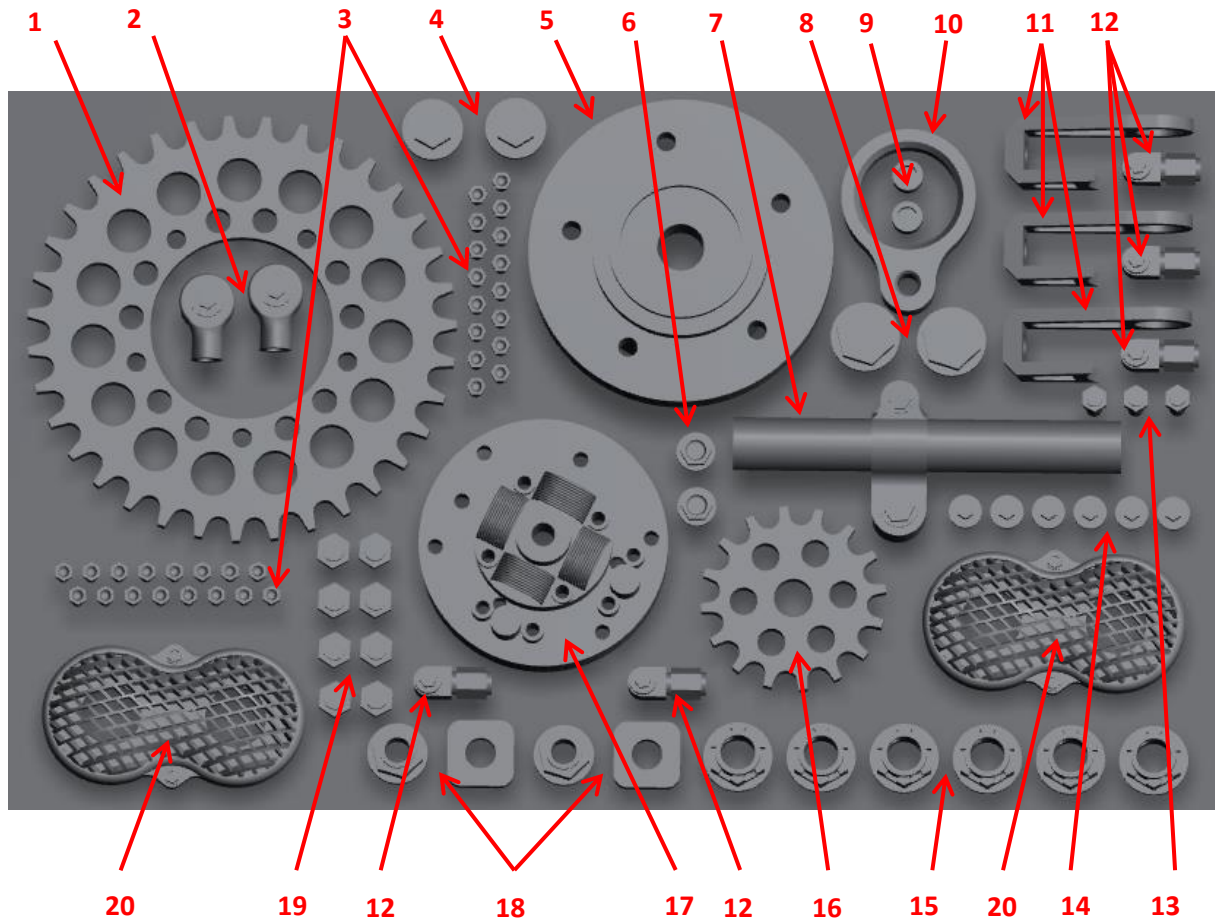

Part no.	Part name	Part no.	Part name
1	Rear sprocket x1	12	Brake hose connector x5
2	Steering damper connector x2	13	Chain tensioner screw
3	Small screws x32	14	Rear break disc screws x6
4	Front sprocket screw x2	15	Front/rear wheel axle nuts x6
5	Rear sprocket adapter x1	16	Front sprocket x1
6	Alternator central screw x2	17	Alternator x1
7	Steering damper cylinder x1	18	Frame fillingsx2
8	Front fork central screw x2	19	Rear sprocket screws x8
9	Steering damper locking nut x2	20	Carburetor mesh cover x2
10	Steering damper fork adapter x1		
11	Chain tensioner x3		

It is suggested to cut off all parts except screws which can be painted as attached to the print base.

Contents

Chain.....	3
Alternator	5
Carburetor mesh cover	6
Front/rear wheel axle nuts.....	7
Frame fillings, chain tensioners and rear brake hose connector	8
Rear brake disc modification.....	11
Steering damper	12

Chain

1. Remove all supports holding the chain. Use sharp cutters like Tamiya 74035. Do not break off the chain. See the video on supports removal at www.falconscalemodels.com in the manual section.
2. Remove all the supports holding rear sprocket screws (19), front sprocket screws (4), sprockets (1, 16) and adapter (5) having in mind rear and front sprocket screws should have an installation pins. Properly cut off parts:

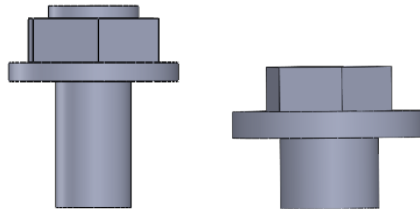

3. After painting install front sprocket screw in the front sprocket using CA glue or Micro Kristal Klear.
It is suggested to use Micro Kristal Klear glue as to excess can be removed with warm water without damaging painted surface.
4. After painting install TWO rear sprocket screws in the rear sprocket using Micro Kristal Klear or similar. DO NOT cut screw installation pin.

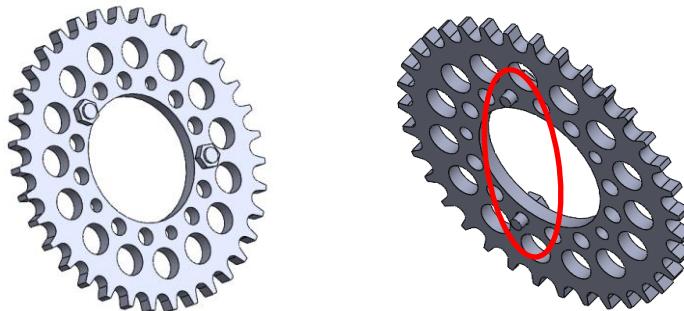

5. Apply small amount of CA glue inside the screw holes in the adapter and joint it with installation pins of screws joined with the rear sprocket.

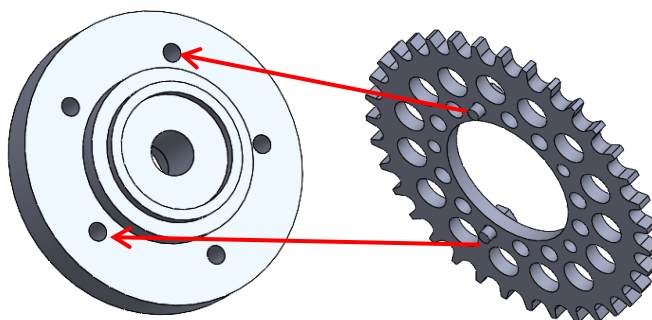

6. Install the remaining three rear sprocket screws.
7. Install the sprockets inside the chain.
See the video on sprocket installation at www.falconscalemodels.com in the manual section.
Gently widen the chain and insert the sprocket onto the central pints of the chain arc.
In the next step, lightly raise the chain and pull it in the direction of the opposite sprocket to

place all the pins on the sprocket. If needed secure the sprockets position using CA glue or Micro Kristal Klear.

8. Split the chain using base kit part as a reference. Cut links one by one. Do not cut all links at once as you can damage the chain.

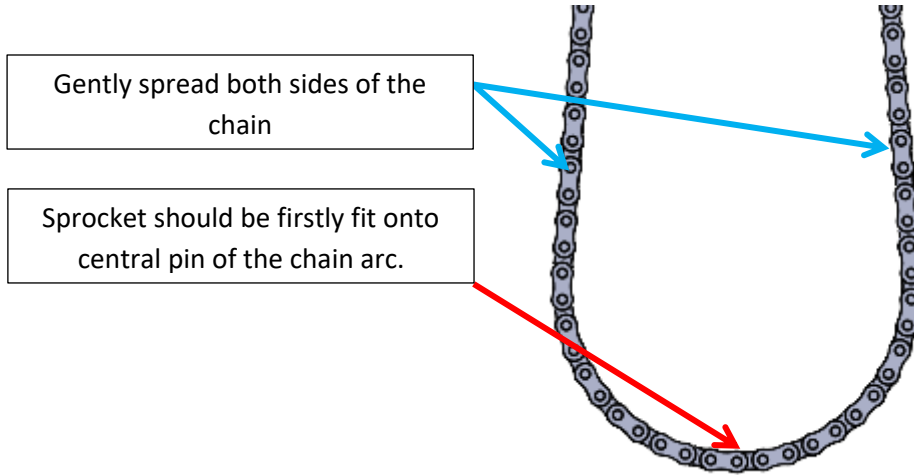

Proper position of the sprocket inside the chain.

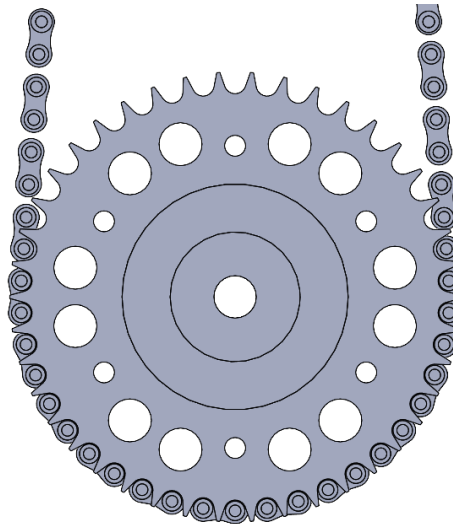

Alternator

1. Remove all supports holding the alternator (17). Use sharp cutters like Tamiya 74035. Do not break off the part.
2. Paint and install alternator central screw (6) using Micro Kristal Klear or similar. CA is not advised at this step.
3. Paint small alternator screws (3) and install them using Micro Kristal Klear or similar and sharp pointed tweezers. Installation holes are marked in green. In case one of the holes is not through shorten screw installation pin.

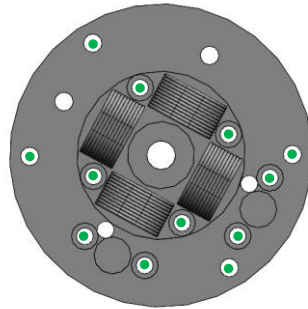

One needs 12 screws for the alternator. FSM P006 kit offers 32 screws so use them freely to upgrade other parts of your bike.

4. Using 0.2mm wire make alternator wiring. Use wire installation hole as starting points with CA glue applied from the back to secure the wire starting position. In the next step remove the insulation from the black wire (about 3mm). Cut the 4mm long black vinyl tube from the base kit. Apply CA glue on wires ends and insert them inside the vinyl tube. Glue the alternator to the engine block and hide the black wire inside the main frame.

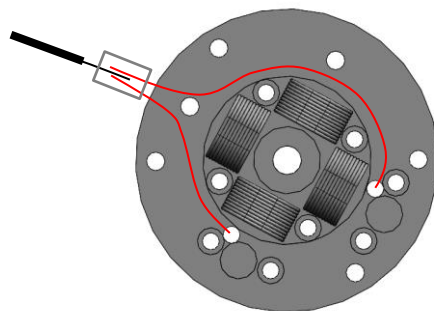

Alternator reference photo:



Carburetor mesh cover

1. Remove all supports holding the carburetor mesh covers (20) which replace base kit parts B10. Use sharp cutters like Tamiya 74035. Do not break off the part.
2. Apply CA glue on the carburetor edges (base kit parts B19) and glue carburetor mesh covers. Use positioning cuts in base of the carburetor mesh covers during this operation.



Carburetor mesh cover reference photo:



Front/rear wheel axle nuts

1. Remove all supports holding nuts (15). Use sharp cutters like Tamiya 74035. Do not break off the part.

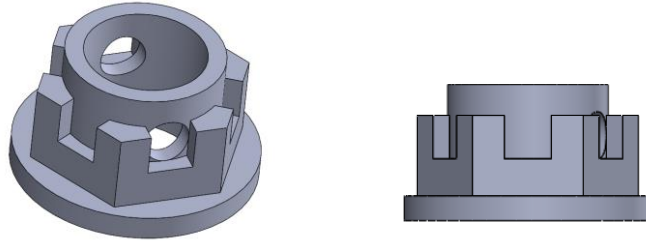

2. Cut thin wire to 10mm long sections.
3. Bend wire in half and pass it through the holes in the nut.
4. Spread wire ends on two sides and secure wire position with CA glue.
5. Cut 2 thick metal tubes to the length of 20mm and use them as axles for front and rear wheels.

REMARK

Part B25:

- smooth the area of axle nut installation,
- using 1.6mm drill bit, correct a hole for wheel axle.

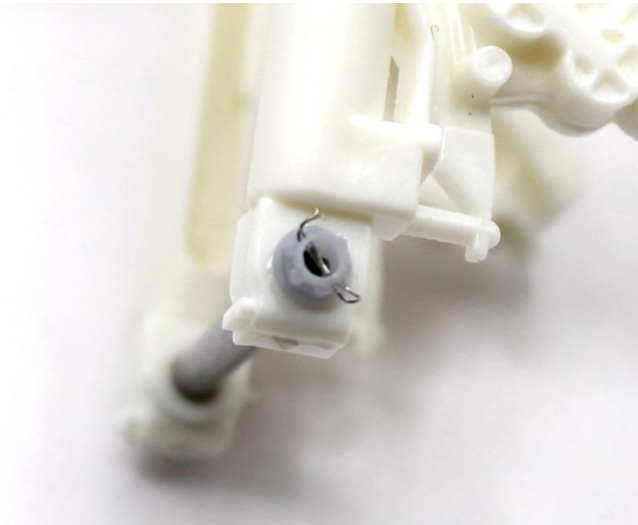

Frame fillings, chain tensioners and rear brake hose connector

1. Shorten thick metal tube to 23mm for swingarm connection with a frame. Smooth cut edges.
2. Using 1.6mm drill bit, drill a through hole in the both side of the swingarm (parts B12 and B21).
3. Using 1.6mm drill bit, correct a hole for rear wheel axle in B21 in case you want to replace base kit screw with nuts from FSM P 006 kit.
4. Make a test fit of metal and plastic parts.
5. Smooth down molded chain tensioners in B12 and B21 and replace them with chain tensioners (11).
6. Using 0.55 – 0.6mm drill bit, drill a hole in the rear side of the swingarm for a chain tensioner screw. Use chain tensioner hole as a guide. Drill 0.5mm deep hole. The hole is needed to hide unevenly cut off chain tensioner screw.
7. Install chain tensioner screws (13).
8. Smooth molded rear brake connector and drill a hole of 0.6mm diameter for a brake hose connector (12).

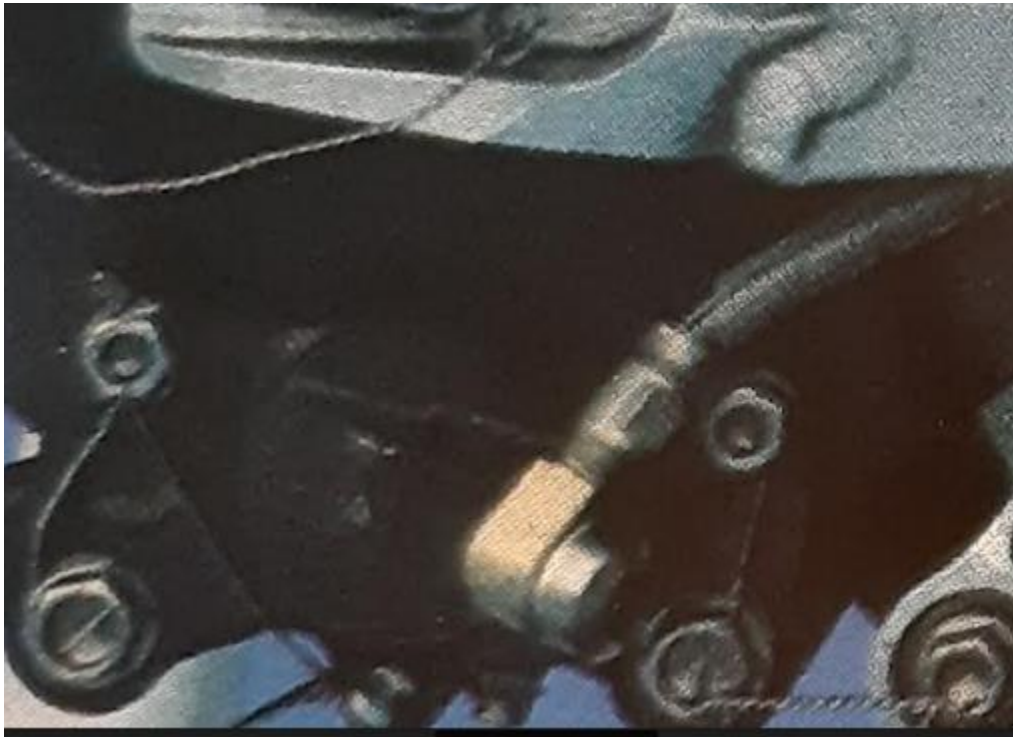

9. Cut 3mm long piece of 0.2mm metal wire and using CA glue, glue it to the brake hose connector as a guide for a vinyl tube imitating brake wire. Repeating steps 8 and 9 one can also upgrade front brake calipers.

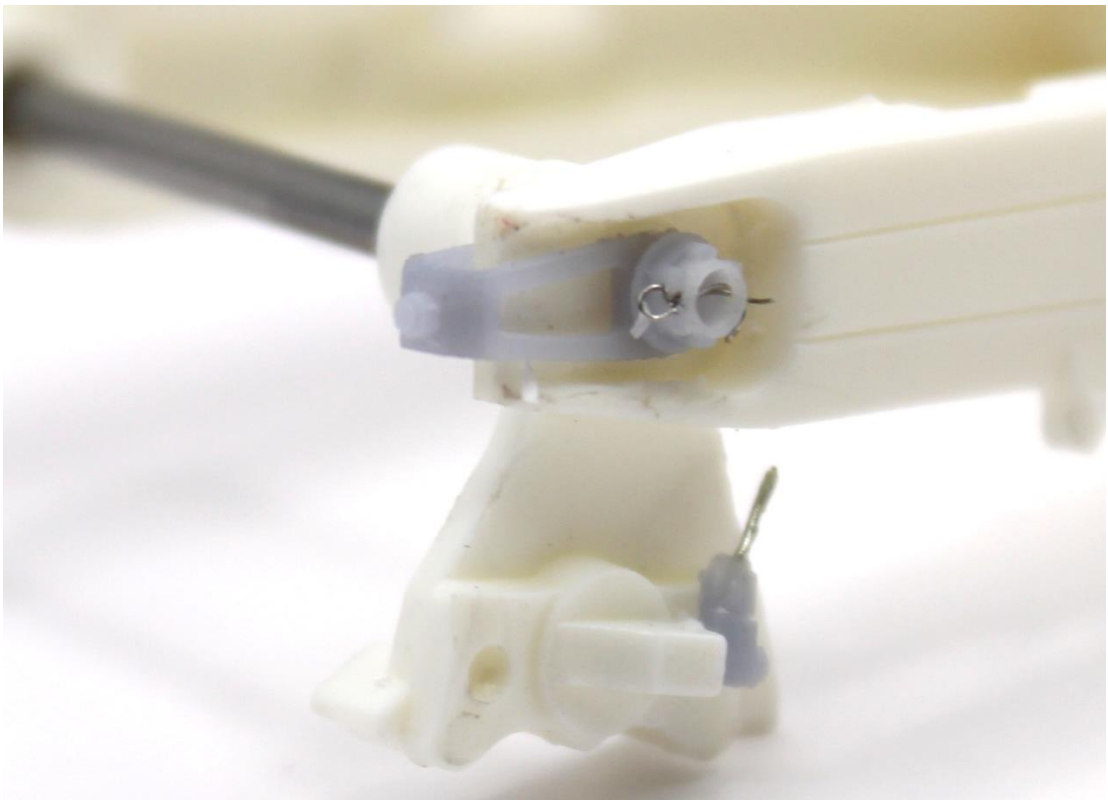
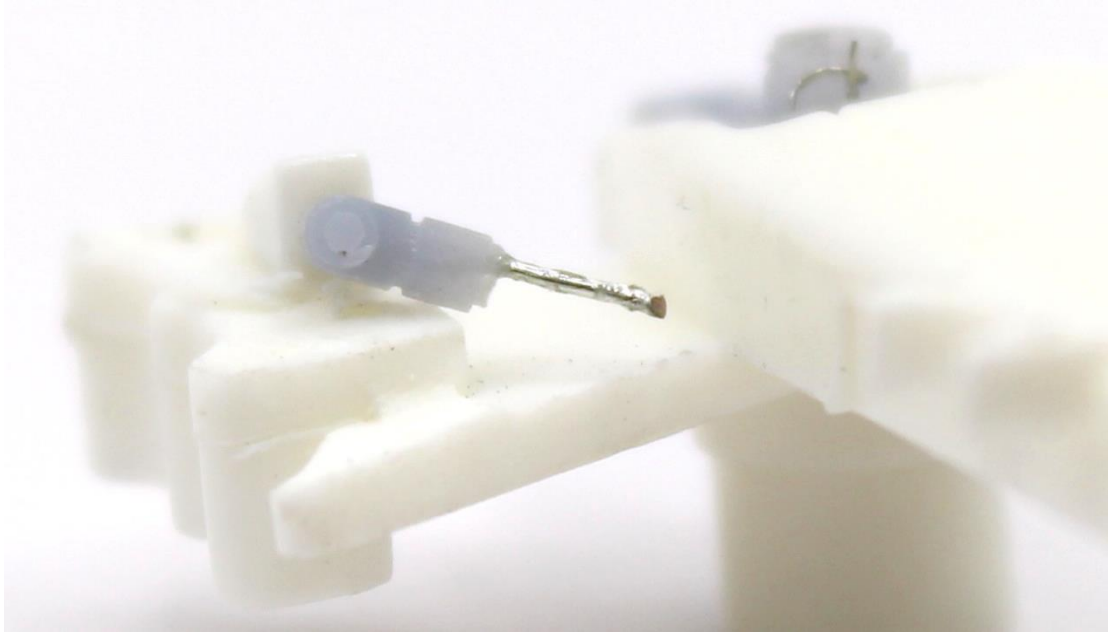

10. Glue both sides of the swingarm (point 4 of the base kit manual). Do not use B26 part as it is replaced with 23mm long metal tube.
11. Install the swingarm inside the main frame and secure it with the 23mm long metal tube. **Metal tube cannot extend beyond plastic parts.** Use parts (18) to fill holes on the sides of the main frame. Parts have no installation pins on the bottom side.

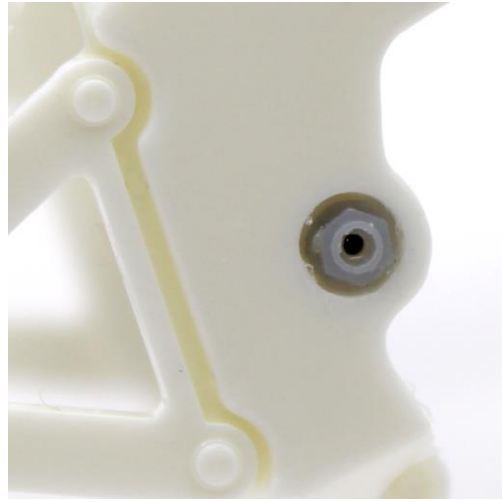
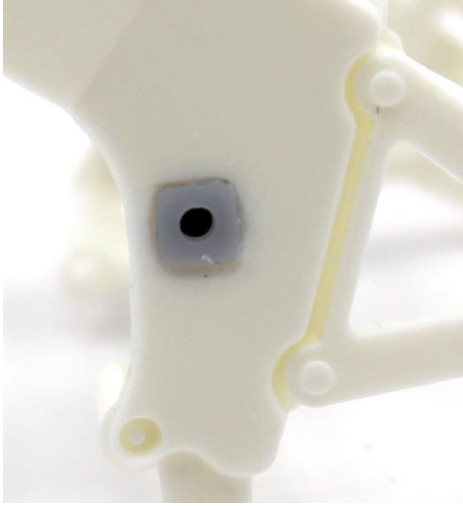

Rear brake disc modification

1. Remove molded screws front the rear brake disc (part C27).
2. Using parts (14) and CA glue or Micro Kristal Klear glue screw heads to the brake disc. Parts (14) have no installation pin.

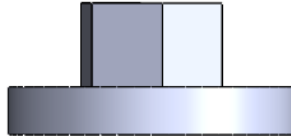

Front fork modification

1. Using 1.6mm drill bit, correct a hole for axle in lower fork yoke – part C22.
2. Cut thick metal tube to the length of 20mm and use it as axle which connects lower and upper fork yokes.
3. Use CA glue to secure axle position. Axle cannot extend above upper fork yoke.
4. Use front fork central screw (8) to cover the installation hole in the upper fork yoke.



Steering damper

1. Remove steering damper cylinder (7) from the supports and using 0.9mm drill bit correct the piston hole.
2. Using CA glue, glue steering damper cylinder (7) to the main frame.
3. Shorten thin metal tube to the length of 25 mm and smooth both ends.
4. Dip one end of the thin metal tube into CA glue and put it inside steering damper locking nut (9).
5. Remove the steering damper connector (2) from the supports. Steering damper connector has an installation pin, so do not cut it off when removing supports.



6. Check if the thin metal rod enters the steering damper connector hole. If not sand down gently metal rod or use 0.5mm followed by 0.6mm drill bit to correct the hole. Do it careful not to break the side walls. Hole depth of 1mm is enough.
7. Pass the thin metal tube through the piston hole in the steering damper cylinder.
8. Using CA glue, glue other end of the thin metal tube with the steering damper connector (2).
9. Remove the steering damper front fork adapter (10) and correct the installation hole using 0.7mm drill bit. Insert steering damper fork adapter (10) onto left front fork tube (base kit part B6) and position it as given in the pictures below and then connect it with steering damper connector (2) WITHOUT GLUE as connector must rotate about the installation hole axis. Turn the front fork few times left and right to be sure that everything moves smoothly and secure the steering damper fork adapter (10) position with CA glue.



